

Fixed Bar Box Scraper

BB1560, BB1566, BB1572, BB2560, BB2566, BB2572, BB2584, & BB2596

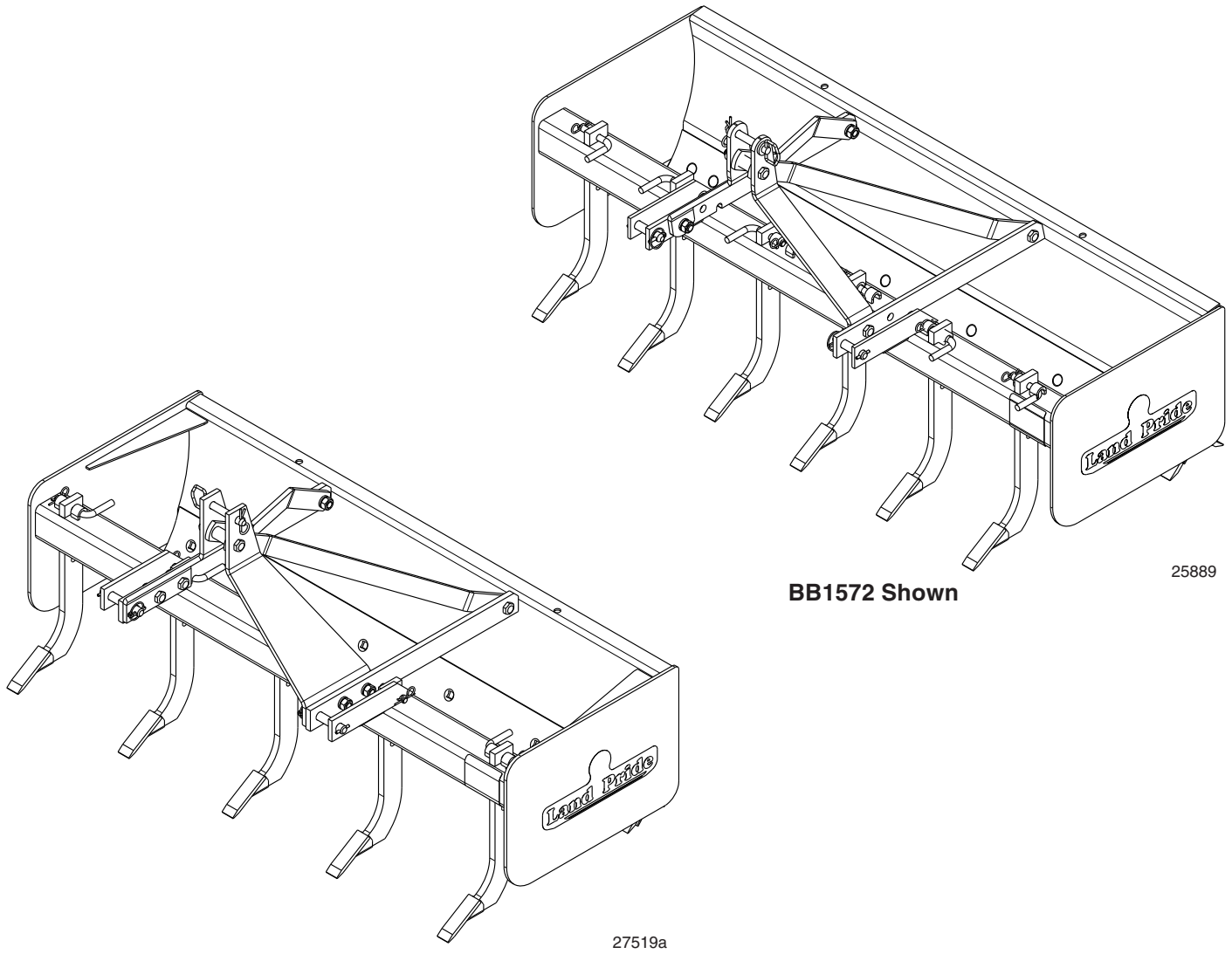

BB2566 Shown

BB1572 Shown

303-082M Operator's Manual



Read the Operator's Manual entirely. When you see this symbol, the subsequent instructions and warnings are serious - follow without exception. Your life and the lives of others depend on it!

Cover photo may show optional equipment not supplied with standard unit.

For an Operator's Manual and Decal Kit in French Language, please see your Land Pride dealer.

Printed 9/25/18



Machine Identification

Record your machine details in the log below. If you replace this manual, be sure to transfer this information to the new manual.

If you, or the dealer, have added Options not originally ordered with the machine, or removed Options that were originally ordered, the weights and measurements are no longer accurate for your machine. Update the record by adding the machine weight and measurements provided in the Specifications & Capacities Section of this manual with the Option(s) weight and measurements.

Model Number	
Serial Number	
Machine Height	
Machine Length	
Machine Width	
Machine Weight	
Delivery Date	
First Operation	
Accessories	<hr/> <hr/> <hr/>

Dealer Contact Information

Name: _____

Street: _____

City/State: _____

Telephone: _____

Email: _____

 California Proposition 65 WARNING: Cancer and reproductive harm - www.P65Warnings.ca.gov

Table of Contents

Important Safety Information	1
Safety at All Times	1
Look for the Safety Alert Symbol	1
Safety Labels	4
Introduction	5
Application	5
Using This Manual	5
Owner Assistance	5
Section 1: Assembly & Set-up	6
Tractor Requirements	6
Torque Requirements	6
Hitch Assembly	6
Shank Assembly	7
3-Point Hook-up	7
Section 2: Operating Procedures	8
Operator's Responsibilities	8
Safety Information	8
Transporting	9
General Operating Instructions	9
Section 3: Adjustments	10
Shank Adjustments	10
Leveling and Pitch Adjustment	10
Section 4: Maintenance	11
Maintenance	11
Shank Tips	11
Cutting Blades	11
Long-Term Storage	12
Ordering Replacement Parts	12
Section 5: Specifications & Capacities	13
Section 6: Features & Benefits	15
Section 7: Torque Values Chart	16
Section 8: Warranty	17



© Copyright 2018 All rights Reserved

Land Pride provides this publication "as is" without warranty of any kind, either expressed or implied. While every precaution has been taken in the preparation of this manual, Land Pride assumes no responsibility for errors or omissions. Neither is any liability assumed for damages resulting from the use of the information contained herein. Land Pride reserves the right to revise and improve its products as it sees fit. This publication describes the state of this product at the time of its publication, and may not reflect the product in the future.

Land Pride is a registered trademark.

All other brands and product names are trademarks or registered trademarks of their respective holders.

Printed in the United States of America.

Table of Contents Continued

See previous page for Table of contents.



Parts Manual QR Locator

The QR (Quick Reference) code on the cover and to the left will take you to the Parts Manual for this equipment. Download the appropriate App on your smart phone, open the App, point your phone on the QR code and take a picture.



Dealer QR Locator

The QR code on the left will link you to available dealers for Land Pride products. Refer to Parts Manual QR Locator on this page for detailed instructions.

Listed below are common practices that may or may not be applicable to the products described in this manual.

Safety at All Times

Careful operation is your best assurance against an accident.

All operators, no matter how much experience they may have, should carefully read this manual and other related manuals, or have the manuals read to them, before operating the power machine and this implement.

- ▲ Thoroughly read and understand the "Safety Label" section. Read all instructions noted on them.
- ▲ Do not operate the equipment while under the influence of drugs or alcohol as they impair the ability to safely and properly operate the equipment.
- ▲ The operator should be familiar with all functions of the tractor and attached implement and be able to handle emergencies quickly.
- ▲ Make sure all guards and shields appropriate for the operation are in place and secured before operating implement.
- ▲ Keep all bystanders away from equipment and work area.
- ▲ Start tractor from the driver's seat with hydraulic controls in neutral.
- ▲ Operate tractor and controls from the driver's seat only.
- ▲ Never dismount from a moving tractor or leave tractor unattended with engine running.
- ▲ Do not allow anyone to stand between tractor and implement while backing up to implement.
- ▲ Keep hands, feet, and clothing away from power-driven parts.
- ▲ While transporting and operating equipment, watch out for objects overhead and along side such as fences, trees, buildings, wires, etc.
- ▲ Do not turn tractor so tight as to cause hitched implement to ride up on the tractor's rear wheel.
- ▲ Store implement in an area where children normally do not play. When needed, secure attachment against falling with support blocks.



Look for the Safety Alert Symbol

The SAFETY ALERT SYMBOL indicates there is a potential hazard to personal safety involved and extra safety precaution must be taken. When you see this symbol, be alert and carefully read the message that follows it. In addition to design and configuration of equipment, hazard control, and accident prevention are dependent upon the awareness, concern, prudence, and proper training of personnel involved in the operation, transport, maintenance, and storage of equipment.

Be Aware of Signal Words

A signal word designates a degree or level of hazard seriousness. The signal words are:

DANGER

Indicates a hazardous situation that, if not avoided, will result in death or serious injury.

WARNING

Indicates a hazardous situation that, if not avoided, could result in death or serious injury.

CAUTION

Indicates a hazardous situation that, if not avoided, may result in minor or moderate injury.

Safety Precautions for Children

Tragedy can occur if the operator is not alert to the presence of children. Children generally are attracted to implements and their work.

- ▲ Never assume children will remain where you last saw them.
- ▲ Keep children out of the work area and under the watchful eye of a responsible adult.
- ▲ Be alert and shut the implement and tractor down if children enter the work area.
- ▲ Never carry children on the tractor or implement. There is not a safe place for them to ride. They may fall off and be run over or interfere with the control of the power machine.
- ▲ Never allow children to operate the power machine, even under adult supervision.
- ▲ Never allow children to play on the power machine or implement.
- ▲ Use extra caution when backing up. Before the tractor starts to move, look down and behind to make sure the area is clear.

Tractor Shutdown & Storage

- ▲ If engaged, disengage power take-off.
- ▲ Park on solid, level ground and lower implement to ground or onto support blocks.
- ▲ Put tractor in park or set park brake, turn off engine, and remove switch key to prevent unauthorized starting.
- ▲ Relieve all hydraulic pressure to auxiliary hydraulic lines.
- ▲ Wait for all components to stop before leaving operator's seat.
- ▲ Use steps, grab-handles and anti-slip surfaces when stepping on and off the tractor.
- ▲ Detach and store implement in an area where children normally do not play. Secure implement using blocks and supports.



Listed below are common practices that may or may not be applicable to the products described in this manual.

Tire Safety

- ▲ Tire changing can be dangerous and must be performed by trained personnel using the correct tools and equipment.
- ▲ Always maintain correct tire pressure. Do not inflate tires above recommended pressures shown in the Operator's Manual.
- ▲ When inflating tires, use a clip-on chuck and extension hose long enough to allow you to stand to one side and NOT in front of or over the tire assembly. Use a safety cage if available.
- ▲ Securely support the implement when changing a wheel.
- ▲ When removing and installing wheels, use wheel handling equipment adequate for the weight involved.
- ▲ Make sure wheel bolts have been tightened to the specified torque.



Transport Safely

- ▲ Comply with federal, state, and local laws.
- ▲ Use towing vehicle and trailer of adequate size and capacity. Secure equipment towed on a trailer with tie downs and chains.
- ▲ Sudden braking can cause a towed trailer to swerve and upset. Reduce speed if towed trailer is not equipped with brakes.
- ▲ Avoid contact with any overhead utility lines or electrically charged conductors.
- ▲ Always drive with load on end of loader arms low to the ground.
- ▲ Always drive straight up and down steep inclines with heavy end of a tractor with loader attachment on the "uphill" side.
- ▲ Engage park brake when stopped on an incline.
- ▲ Maximum transport speed for an attached equipment is 20 mph. DO NOT EXCEED. Never travel at a speed which does not allow adequate control of steering and stopping. Some rough terrains require a slower speed.
- ▲ As a guideline, use the following maximum speed weight ratios for attached equipment:
 - 20 mph when weight of attached equipment is less than or equal to the weight of machine towing the equipment.
 - 10 mph when weight of attached equipment exceeds weight of machine towing equipment but not more than double the weight.
- ▲ **IMPORTANT:** Do not tow a load that is more than double the weight of the vehicle towing the load.

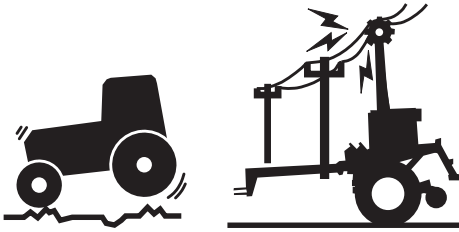

Use A Safety Chain

- ▲ A safety chain will help control drawn machinery should it separate from the tractor drawbar.
- ▲ Use a chain with the strength rating equal to or greater than the gross weight of the towed implement.
- ▲ Attach the chain to the tractor drawbar support or other specified anchor location. Allow only enough slack in the chain to permit turning.
- ▲ Always hitch the implement to the machine towing it. Do not use the safety chain tow the implement.



Practice Safe Maintenance

- ▲ Understand procedure before doing work. Refer to the Operator's Manual for additional information.
- ▲ Work on a level surface in a clean dry area that is well-lit.
- ▲ Lower implement to the ground and follow all shutdown procedures before leaving the operator's seat to perform maintenance.
- ▲ Do not work under any hydraulic supported equipment. It can settle, suddenly leak down, or be lowered accidentally. If it is necessary to work under the equipment, securely support it with stands or suitable blocking beforehand.
- ▲ Use properly grounded electrical outlets and tools.
- ▲ Use correct tools and equipment for the job that are in good condition.
- ▲ Allow equipment to cool before working on it.
- ▲ Disconnect battery ground cable (-) before servicing or adjusting electrical systems or before welding on implement.
- ▲ Inspect all parts. Make certain parts are in good condition & installed properly.
- ▲ Replace parts on this implement with genuine Land Pride parts only. Do not alter this implement in a way which will adversely affect its performance.
- ▲ Do not grease or oil implement while it is in operation.
- ▲ Remove buildup of grease, oil, or debris.
- ▲ Always make sure any material and waste products from the repair and maintenance of the implement are properly collected and disposed.
- ▲ Remove all tools and unused parts before operation.
- ▲ Do not weld or torch on galvanized metal as it will release toxic fumes.



Important Safety Information

Listed below are common practices that may or may not be applicable to the products described in this manual.

Prepare for Emergencies

- ▲ Be prepared if a fire starts.
- ▲ Keep a first aid kit and fire extinguisher handy.
- ▲ Keep emergency numbers for doctor, ambulance, hospital, and fire department near phone.



Use Safety Lights and Devices

- ▲ Slow moving tractors, skid steers, self-propelled machines, and towed equipment can create a hazard when driven on public roads. They are difficult to see, especially at night. Use the Slow Moving Vehicle sign (SMV) when on public roads.
- ▲ Flashing warning lights and turn signals are recommended whenever driving on public roads.

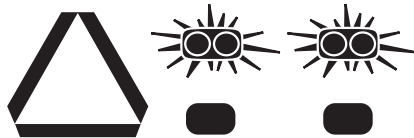

Avoid Underground Utilities

- ▲ **Dig Safe, Call 811 (USA).** Always contact your local utility companies (electrical, telephone, gas, water, sewer, and others) before digging so that they may mark the location of any underground services in the area.
- ▲ Be sure to ask how close you can work to the marks they positioned.



Wear Personal Protective Equipment (PPE)

- ▲ Wear protective clothing and equipment appropriate for the job such as safety shoes, safety glasses, hard hat, and ear plugs.
- ▲ Clothing should fit snug without fringes and pull strings to avoid entanglement with moving parts.
- ▲ Prolonged exposure to loud noise can cause hearing impairment or hearing loss. Wear suitable hearing protection such as earmuffs or earplugs.
- ▲ Operating equipment safely requires the operator's full attention. Avoid wearing headphones while operating equipment.



Use Seat Belt and ROPS

- ▲ Land Pride recommends the use of a CAB or roll-over-protective-structures (ROPS) and seat belt in almost all power machines. Combination of a CAB or ROPS and seat belt will reduce the risk of serious injury or death if the power machine should be upset.
- ▲ If ROPS is in the locked-up position, fasten seat belt snugly and securely to help protect against serious injury or death from falling and machine overturn.

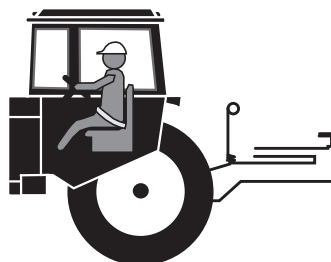

Avoid High Pressure Fluids Hazard

- ▲ Escaping fluid under pressure can penetrate the skin causing serious injury.
- ▲ Before disconnecting hydraulic lines or performing work on the hydraulic system, be sure to release all residual pressure.
- ▲ Make sure all hydraulic fluid connections are tight and all hydraulic hoses and lines are in good condition before applying pressure to the system.
- ▲ Use a piece of paper or cardboard, NOT BODY PARTS, to check for suspected leaks.
- ▲ Wear protective gloves and safety glasses or goggles when working with hydraulic systems.
- ▲ **DO NOT DELAY.** If an accident occurs, see a doctor familiar with this type of injury immediately. Any fluid injected into the skin or eyes must be treated within a few hours or gangrene may result.



Keep Riders Off Machinery

- ▲ Never carry riders on tractor or implement.
- ▲ Riders obstruct operator's view and interfere with the control of the power machine.
- ▲ Riders can be struck by objects or thrown from the equipment.
- ▲ Never use tractor or implement to lift or transport riders.

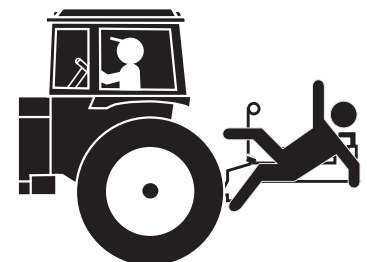

Important Safety Information

Safety Labels

Your Box Scraper comes equipped with all safety labels in place. They were designed to help you safely operate your implement. Read and follow their directions.

1. Keep all safety labels clean and legible.
2. Refer to this section for proper label placement. Replace all damaged or missing labels. Order new labels from your nearest Land Pride dealer. To find your nearest dealer, visit our dealer locator at www.landpride.com.
3. Some new equipment installed during repair requires safety labels to be affixed to the replaced component as

specified by Land Pride. When ordering new components make sure the correct safety labels are included in the request.

4. Refer to this section for proper label placement. To install new labels:
 - a. Clean surface area where label is to be placed.
 - b. Spray soapy water onto the cleaned area.
 - c. Peel backing from label and press label firmly onto the surface.
 - d. Squeeze out air bubbles with edge of a credit card or with a similar type of straight edge.

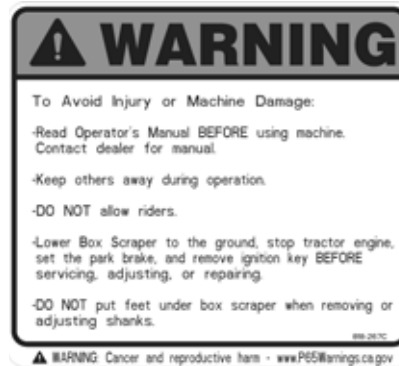
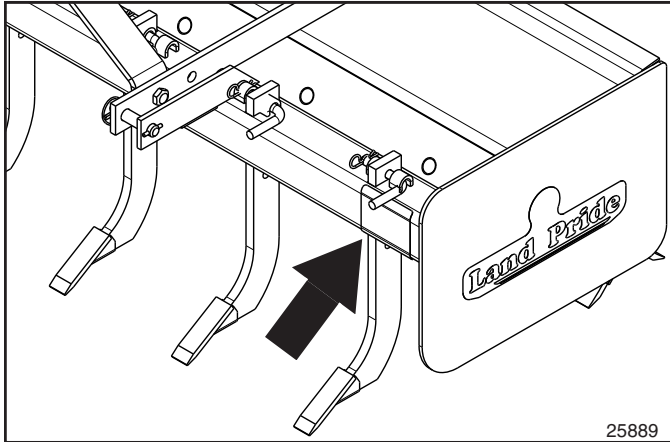

818-267C

Caution Avoid Injury

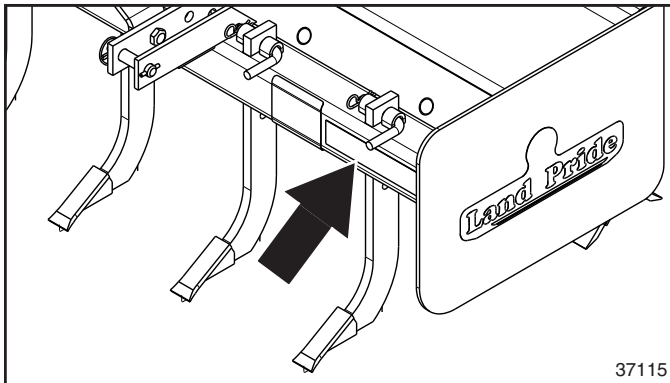

838-615C

BB2596 Only

2" x 9" Amber Reflector (1 place)

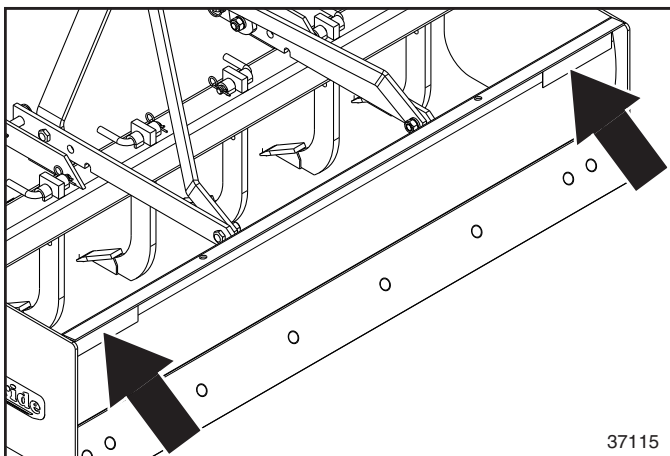

838-614C

BB2596 Only

2" x 9" Red Reflector (2 places)

Introduction

Land Pride welcomes you to the growing family of new product owners. This Box Scraper has been designed with care and built by skilled workers using quality materials. Proper assembly, maintenance, and safe operating practices will help you get years of satisfactory use from this implement.

Application

The Land Pride 15 and 25 Series Fixed Bar Box Scrapers are designed for Category 1 - three point hitch or Quick Hitch System mounting. The 15 series is adapted for attachment to tractors in the 17-40 horsepower range and the 25 series is adapted for tractors in the 25-55 horsepower range.

These Fixed Bar Box Scrapers are ideal for ripping, leveling, finish grading, and backfilling applications at feedlots, outdoor arenas, building sites, and maintenance operations on farm and ranch lanes or roadways.

See “**Specifications & Capacities**” on page 12 and “**Features & Benefits**” on page 15 for additional information and performance enhancing options.

Using This Manual

- This Operator’s Manual is designed to help familiarize the operator with safety, assembly, operation, adjustments, troubleshooting, and maintenance. Read this manual and follow the recommendations to help ensure safe and efficient operation.
- The information contained within this manual was current at the time of printing. Some parts may change slightly to assure you of the best performance.
- To order a new Operator’s or Parts Manual, contact your authorized dealer. Manuals can also be downloaded, free-of-charge, from our website at www.landpride.com

Terminology

“Right” or “Left” as used in this manual is determined by facing forward in the direction the machine will operate while in use unless otherwise stated.

Definitions

IMPORTANT: A special point of information related to the following topic. Land Pride’s intention is this information must be read & noted before continuing.

NOTE: A special point of information that the operator should be aware of before continuing.

Owner Assistance

The dealer should complete the Online Warranty Registration at the time of purchase. This information is necessary to provide you with quality customer service.

The parts on your Box Scraper have been specially designed by Land Pride and should only be replaced with genuine Land Pride parts. Contact a Land Pride dealer if customer service or repair parts are required. Your Land Pride dealer has trained personnel, repair parts, and equipment needed to service the implement.

Serial Number

For quick reference and prompt service, record model and serial number on the inside cover page and again on the warranty page. Always provide model number and serial number when ordering parts and in all correspondences with your Land Pride dealer. For location of your serial number plate, see Figure 1.

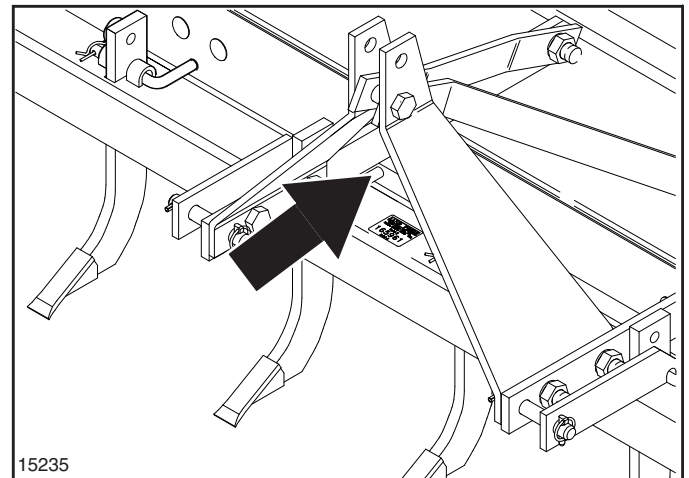

Serial Number Plate Location
Figure 1

Further Assistance

Your dealer wants you to be satisfied with your new Box Scraper. If for any reason you do not understand any part of this manual or are not satisfied with the service received, the following actions are suggested:

1. Discuss any problems you have with your implement with your dealership service personnel so they can address the problem.
2. If you are still not satisfied, seek out the owner or general manager of the dealership, explain the question/problem, and request assistance.
3. For further assistance write to:

Land Pride Service Department
1525 East North Street

P.O. Box 5060
Salina, Ks. 67402-5060

E-mail address
lp servicedept@landpride.com

Section 1: Assembly & Set-up

Tractor Requirements

Tractor horsepower should be within the range noted below. Tractors outside the horsepower range must not be used.

Horsepower {Maximum}	
BB15	40 power take-off
BB25	55 power take-off
Hitch Type	3-point Cat. 1

WARNING

To avoid serious injury or death:

Lightweight tractors with rear attached implements may need weights added to the front to maintain steering control. Consult your tractor Operator's Manual to determine proper weight requirements and maximum weight limitations.

Torque Requirements

Refer to "Torque Values Chart" on page 16 to determine correct torque values when tightening hardware.

Hitch Assembly

Refer to Figure 1-1:

1. Attach 3-point hitch straps (#1) & hitch braces (#2) to Box Scraper frame with 3/4"-10 x 2" GR5 bolts (#3), lock washers (#4), and hex nuts (#5). **Do not tighten nuts** at this time.
2. (BB25 Only) Align hitch straps (#1) with lower hitch holes to allow hitch pins (#6) to pass through.

IMPORTANT: (BB25 & BB15) Hitch straps (#1) must be oriented with upper middle hole in the most forward position for a Quick Hitch to fit correctly.

3. Align upper middle holes in hitch straps (#1) with holes in hitch braces (#2) as shown. With 2" long spacer (#10) positioned in the center, insert 3/4"-10 x 5" GR5 hex cap screw (#11) through hitch braces, straps, and spacer. Secure bolt with lock washer (#12) and hex nut (#13).
4. When hitch is attached it will form an A-frame. Make sure the A-frame is positioned square to the Box Scraper frame and then tightening assembly hardware to the correct torque.

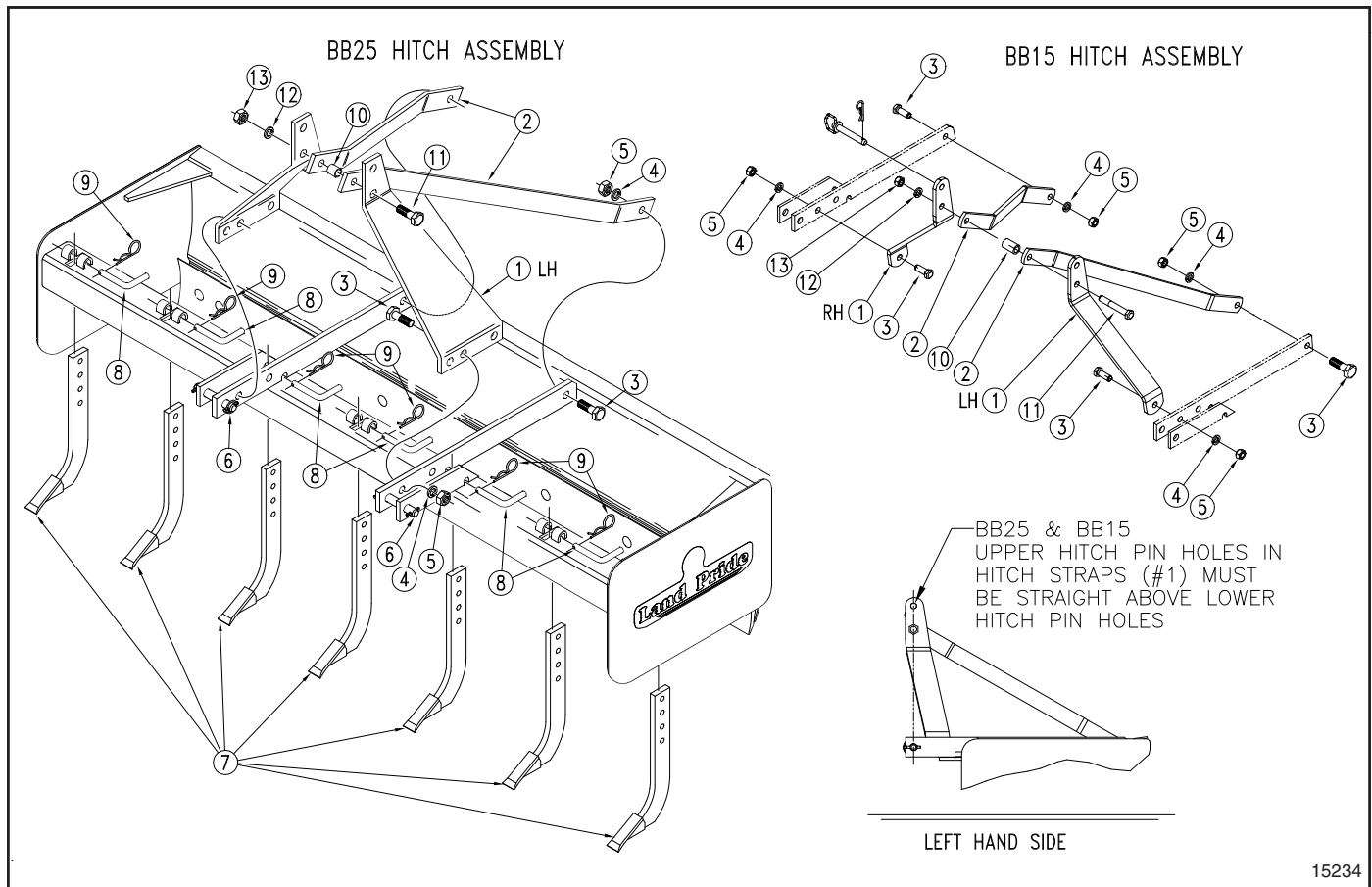

**Hitch & Shank Assembly
Figure 1-1**

Section 1: Assembly & Set-up**Shank Assembly****⚠ DANGER**

To avoid serious injury or death:

Make adjustments to the implement after it has been properly attached to a tractor and secured with solid non-concrete supports in the up position. Never work around or under equipment supported by hydraulics. Hydraulics can drop equipment instantly if controls are actuated or if hydraulic lines burst even when power to hydraulics is shut off.

⚠ WARNING

To avoid serious injury or death:

- Always keep your body extremities out from under the shanks while adjusting them. It is possible for the shanks to fall causing injury to your feet and/or legs.
- Keep clear of the shank slots while adjusting shank height. Shanks can pinch body parts in the slots during adjustments.

Refer to **Figure 1-1** on page 6:

1. Before installing shanks (#3), manually raise front shank tube (#1) up to insert shanks from the bottom or attach scraper to a tractor's 3-point hitch and raise unit up with tractor's 3-point lift arms.
2. Securely support scraper in the raised position with support jacks or blocks.
3. With shank tips pointing forward, insert shanks (#7) into the bottom slots in shank tube.
4. Push each shank up until the lowest hole in the shank is aligned with lock pin (#8) hitch holes.
5. Secure shanks with lock pins (#8) and hairpin cotters (#9).

NOTE: See "Shank Adjustments" on page 10 for instructions on how to adjust shank depth.

3-Point Hook-up**⚠ DANGER**

To avoid serious injury or death:

A crushing hazard exists while hooking-up and unhooking implement. Keep people and animals away while backing-up to implement or pulling away from implement. Do not operate hydraulic controls while a person or animal is directly behind the power machine or near the implement.

⚠ WARNING

To avoid serious injury or death:

- Lightweight tractors with rear attached implements may need weights added to the front to maintain steering control. Consult your tractor Operator's Manual to determine proper weight requirements and maximum weight limitations.

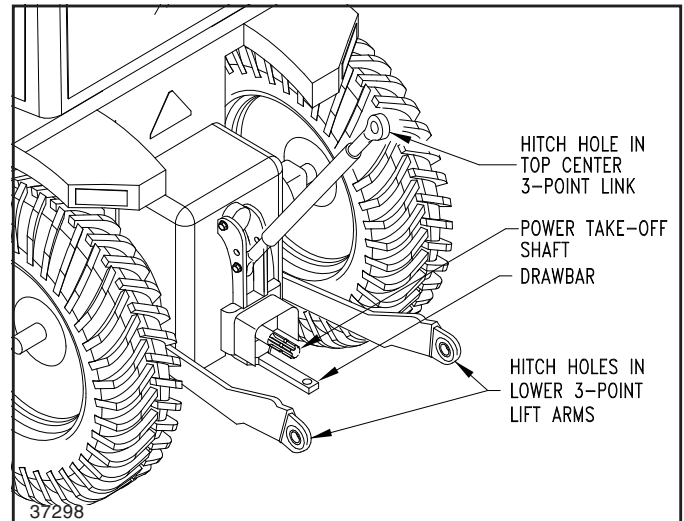

Tractor 3-Point Hitch
Figure 1-2

- Always shut tractor down using "Tractor Shutdown Procedure" provided in this manual before allowing anyone including the operator to hook-up and unhook implement.

NOTE: Land Pride's Quick Hitch can be attached to the tractor to provide quick and easy 3-point hook-up and detachment. See your nearest Land Pride dealer to purchase a Quick-Hitch.

Refer to **Figure 1-2:**

A 3-point Category I hitch is required. The lower 3-point arms of the 3-point hitch must be stabilized to prevent side-to-side movement. Most tractors have sway blocks or adjustable chains for this purpose.

1. Slowly back tractor up to the Box Scraper and use tractor's 3-point hydraulic control to align lower hitch link holes with clevis lug holes on the Box Scraper.
2. Engage tractor park brake, shut tractor engine off, and remove key before dismounting from tractor.
3. With tractor's lower hitch arms aligned and positioned in the clevises, attach lower arms to the clevises with hitch pins and secure with linchpins.
4. Connect top center link to the upper hitch using clevis pin and hairpin cotter.
5. Return to the tractor and slowly operate the tractor's 3-point hydraulic control up and down to check for clearance between the tires, frame, drawbar etc. Move or remove drawbar if it interferes with the Box Scraper.
6. Manually adjust one of the two lower lift arms up or down to level the Box Scraper from left to right.
7. Manually adjust the length of the top-link to level the Box Scraper from front to rear.
8. Ensure that the lower arms are blocked to prevent excessive side movement.

Section 2: Operating Procedures

Operator's Responsibilities

Hazard control and accident prevention are dependent upon the awareness, concern, prudence, and proper training involved in the operation, transport, storage, and maintenance of the Box Scraper. Therefore, it is absolutely essential that no one operates the Box Scraper unless they are age 16 or older and have read, fully understood, and are totally familiar with the Operator's Manual. Make sure the operator has paid particular attention to:

Perform the following inspections before using your Fixed Bar Box Scraper.

Operating Checklist

✓	Check	Page
	Read and follow all Safety Rules carefully. Refer to "Important Safety Information".	1
	Make sure all guards and shields are in place. Refer to "Important Safety Information".	1
	Make sure there are no hydraulic leaks. Refer to "Avoid High Pressure Fluids Hazard".	3
	Read and follow all operating instructions. Make sure operator understands how to operate the Box Scraper. Refer to "Section 2: Operating Procedures".	8
	Read and make all required adjustments. Be sure all pins have been installed and secured. Refer to "Section 3: Adjustments".	10
	Read and follow all Maintenance Instructions. Refer to "Section 4: Maintenance".	11
	Check Box Scraper initially and periodically for loose bolts and pins. Refer to "Torque Values Chart".	16

Safety Information

DANGER

To avoid serious injury or death:

- Allow only persons to operate this implement who have fully read and comprehended this manual, who have been properly trained in the safe operation of this implement, and who are age 16 or older. Serious injury or death can result from the inability to read, understand, and follow instructions provided in this manual.
- Make adjustments to the implement after it has been properly attached to a tractor and secured with solid non-concrete supports in the up position. Never work around or under equipment supported by hydraulics. Hydraulics can drop equipment instantly if controls are actuated or if hydraulic lines burst even when power to hydraulics is shut off.
- Never make contact with underground utilities such as electrical power lines, gas lines, phone lines, etc. They can cause serious injury or death from electrocution, explosion, or fire. If in doubt, call 811 (USA) before digging so that they can mark the location of underground services in the area. For contact information, see Dig Safe in the "Important Safety Information" starting on page 1.

- Do not allow anyone near the tractor or implement while operating. Stop operation if bystanders are too close. They can be hit by flying projectiles, become entangled in the equipment, or ran over.
- Always secure equipment with solid, non-concrete supports before working under it. Never go under equipment supported by concrete blocks or hydraulics. Concrete can break, hydraulic lines can burst, and/or hydraulic controls can be actuated even when power to hydraulics is off.

WARNING

To avoid serious injury or death:

- Never carry riders on the implement or tractor. Riders can obstruct the operator's view, interfere with control of the equipment, be pinched by moving components, become entangled in rotating components, be struck by objects, be thrown or fall from the equipment, etc.
- Allow only persons to operate this implement who have fully read and comprehended this manual, who have been properly trained in the safe operation of this implement, and who are age 16 or older. Serious injury or death can result from the inability to read, understand, and follow instructions provided in this manual.
- Always keep your body extremities out from under the implement. Hydraulics can drop the implement if a line burst or if lift controls are accidentally actuated.
- Do not use implement to lift objects; to pull objects such as fence posts, stumps, etc; or to push objects. The unit is not designed or guarded for these uses.
- Do not use implement to tow other equipment unless it is designed with a tow hitch. Doing so can result in loss of control and damage the equipment.
- Do not use implement as a man lift, work platform or as a wagon to carry objects. It is not properly designed or guarded for this use.
- Perform scheduled maintenance. Check for loose hardware, missing parts, broken parts, structural cracks, and excessive wear. Make repairs before putting implement back into service. Serious breakdowns can result in injury or death.
- Do not alter implement or replace parts on the implement with other brands. Other brands may not fit properly or meet OEM (Original Equipment Manufacturer) specifications. They can weaken the integrity and impair the safety, function, performance, and life of the implement. Replace parts only with genuine OEM parts.
- Make sure safety labels are in their proper location and are in good condition before operating the attached implement. Read and obey all instructions on the labels.

Section 2: Operating Procedures

Transporting

WARNING

To avoid serious injury or death:

- When traveling on roadways, transport in such a way that other vehicles may pass you safely. Use accessory lights, clean reflectors, and a slow moving vehicle sign that is visible from the back to warn operators in other vehicles of your presence. Always comply with all federal, state, and local laws.
 - Select a safe ground speed when transporting. Never travel at a speed which does not allow adequate control of steering and stopping, and never exceed 20 mph (32.2 km/h) with attached equipment. Rough terrain requires a slower speed.
 - Reduce ground speed when turning and leave enough clearance to avoid making contact with obstacles such as buildings, trees, fences, etc. Making contact can result in equipment damage and cause serious injury or death.
 - Make sure implement does not block tractor's Slow Moving Vehicle (SMV) sign when transporting on a public road. If operators in vehicles approaching from the back cannot easily see the sign, then install one on the implement that is visible to warn of your presence.
1. Be sure to reduce tractor ground speed when turning; and leave enough clearance so the Box Scraper does not contact obstacles such as buildings, trees, or fences.
 2. Select a safe ground travel speed when transporting from one area to another.
 3. When traveling on roadways, transport in such a way that faster moving vehicles may pass you safely.
 4. When traveling over rough or hilly terrain, shift tractor to a lower gear.

General Operating Instructions

Once you have familiarized yourself with the Operator's Manual, completed the operations checklist, and properly attached your Land Pride Fixed Bar Box Scraper to your tractor, you are now almost ready to begin work. Fixed Bar Box Scrapers are ideal for ripping, leveling, finish grading, and backfilling applications at feedlots, outdoor arenas, building sites, and maintenance operations on farm and ranch lanes or roadways. Hopefully you have checked out your work site for any buried utility cables, pipelines, or other obstacles that you wouldn't want to damage or encounter.

A Box Scraper's primary purpose is grading and leveling. This function is best done at an approximate 2 to 4mph ground speed. With the ripper shanks raised all the way up, simply lower the Box Scraper to the ground and proceed forward. The grader blade should immediately begin shaving the soil surface and dirt or aggregate material should begin accumulating in the box. You can transfer this material by dragging it to a nearby location and then raising the Box Scraper to deposit your load. You can also achieve uniform distribution and leveling of scraped material by setting the Box Scraper to shave off high spots allowing accumulated material to flow out under the grader blade in the low spots. Occasionally the ground or surface material will be very hard and will require ripping to loosen the soil profile in order for the Box Scraper blade to be effective. If more aggressive ripping action is desired, lower the shanks by 2" increments at a time. If less aggressive ripping action is desired, raise all of the shanks. Achieving the desired effect will require a little experimentation and experience in your given conditions. Box Scrapers generally perform better in dry to slightly damp soil conditions.

Your Land Pride Fixed Bar Box Scraper can also be used for backfilling applications. Simply lower your Box Scraper and back the standard rear facing grader blade into the pile of dirt you are using for backfill. Continue backfilling and pushing operations until you have successfully completed the task.

With a little practice you should become a very good operator and consistently achieve the desired results you expect with your Land Pride Box Scraper.

See "**Specifications & Capacities**" on page 12 and "**Features & Benefits**" on page 15 for additional information and performance enhancing options.

Section 3: Adjustments

Shank Adjustments

DANGER

To avoid serious injury or death:

Make adjustments to the implement after it has been properly attached to a tractor and secured with solid non-concrete supports in the up position. Never work around or under equipment supported by hydraulics. Hydraulics can drop equipment instantly if controls are actuated or if hydraulic lines burst even when power to hydraulics is shut off.

WARNING

To avoid serious injury or death:

- Always keep your body extremities out from under the shanks while adjusting them. It is possible for the shanks to fall causing injury to your feet and/or legs.
- Keep clear of the shank slots while adjusting shank height. Shanks can pinch body parts in the slots during adjustments.

Refer to Figure 3-1:

Shank settings are based on the vertical distance measured from bottom edge of side plates to bottom of shank tips. Adjust each shank height as follows:

1. Remove hairpin cotter (#1) and shank pin(#2).
2. Adjust shank (#3) up or down to the desired hole setting and then replace shank pin and secure with hairpin cotter.

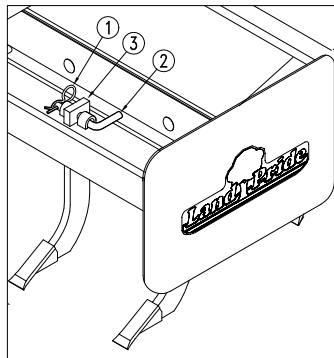

Top Hole
3 3/4" Below Bottom Edge of Side Plate

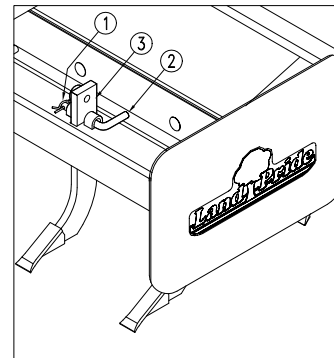

Second Hole
1 3/4" Below Bottom Edge of Side Plate

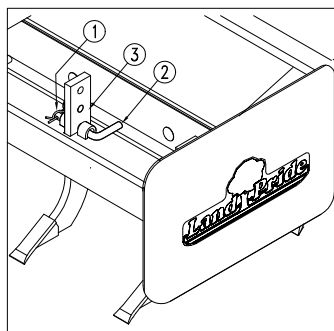

Third Hole
1/4" Above Bottom Edge of Side Plate

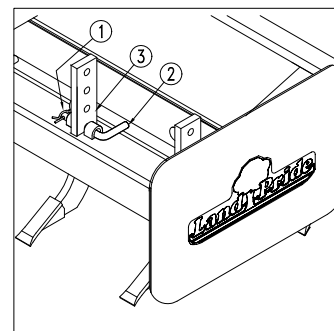

Fourth Hole
2 1/4" Above Bottom Edge of Side Plate

Shank Adjustments
Figure 3-1

Leveling and Pitch Adjustment

Level and pitch adjustments are the same for all models.

1. With shanks raised fully up, locate tractor and Fixed Bar Box Scraper on a flat level surface and then lower scraper down onto the level surface.
2. Place tractor in park, set park brake, shut tractor engine off, and remove switch key.
3. Place a level on the longer front Shank Bar.
4. Manually adjust either one or both of the tractor's lower 3-point arms up or down to level the scraper from left to right. Some tractors have only one arm that is adjustable.
5. Rotate level 90 degrees and then adjust the tractor's top center link until unit is leveled from front to back.

NOTE: Through extensive research and testing, Land Pride has designed the optimum cutting angle into your Box Scraper. If needed, shorten top center link one-half turn at time to increase blade pitch.

15236

Section 4: Maintenance**Maintenance**

Proper servicing and adjustments are key to the long life of any implement. With careful inspection and routine maintenance, you can avoid costly downtime and repair.

Check all bolts after using the unit for several hours to be sure they are tight. Replace any worn, damaged, or illegible safety labels by obtaining new labels from your Land Pride dealer.

DANGER

To avoid serious injury or death:

Always secure equipment with solid, non-concrete supports before working under it. Never go under equipment supported by concrete blocks or hydraulics. Concrete can break, hydraulic lines can burst, and/or hydraulic controls can be actuated even when power to hydraulics is off.

WARNING

To avoid serious injury or death:

- *Allow only persons to perform maintenance on this implement who have been properly trained in its safe operation.*
- *Perform scheduled maintenance. Check for loose hardware, missing parts, broken parts, structural cracks, and excessive wear. Make repairs before putting implement back into service. Serious breakdowns can result in injury or death.*
- *Do not alter implement or replace parts on the implement with other brands. Other brands may not fit properly or meet OEM (Original Equipment Manufacturer) specifications. They can weaken the integrity and impair the safety, function, performance, and life of the implement. Replace parts only with genuine OEM parts.*
- *Always keep your body extremities out from under the shanks and cutting blades while removing, installing, and adjusting them. It is possible for the cutting blades and/or shanks to fall causing injury to your body.*

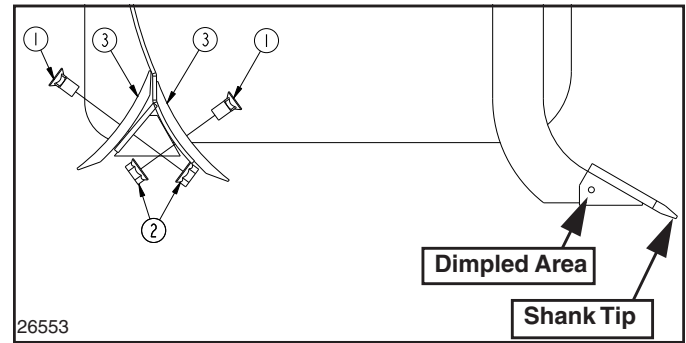

Cutting Blade Removal and Shank Tip Removal

Figure 4-1

Shank Tips

Refer to Figure 4-1:

Shank tips are removable by heating them in the dimpled area on both sides and knocking them off with a blunt punch. New shank tips need to be dimpled with a punch after they are installed.

Cutting Blades

Refer to Figure 4-1:

The front and rear cutting blades (#3) have two cutting edges. Replace cutting blades when both edges are worn out.

1. Unbolt cutting blade (#3) and turn it over when its bottom cutting edge wears out.
2. Inspect 5/8" -11 x 1 1/4" GR5 plow bolts (#1) and hex flange locknuts (#2) for wear. Replace as needed.

Reattach blade (#3) and torque nuts to the correct torque.

Section 4: Maintenance

Long-Term Storage

Clean, inspect, service, and make necessary repairs to the implement when storing it for long periods and at the end of the season. This will help ensure the unit is ready for field use the next time you hook-up to it.

1. Clean off any dirt that may have accumulated on the scraper and cutting blade. Scrape off compacted dirt and then wash surfaces thoroughly with a garden hose.
2. Check Shank Bars and plow bolts for wear and replace if necessary. For additional instructions, see “**Cutting Blades**” on this page.
3. Inspect Box Scraper for loose, damaged, or worn parts. Adjust and tighten loose parts. When needed, replace parts with genuine Land Parts only.
4. Repaint parts where paint is worn or scratched to prevent rust. Ask your dealer for Land Pride aerosol touch-up paint. They are also available in touch-up bottles with brush, quarts, and gallon sizes by adding TU, QT, or GL to the end of the aerosol part number.

Land Pride Aerosol Touch-up Paint	
Part No.	Part Description
821-011C	PAINT LP BEIGE SPRAY CAN
821-054C	PAINT MEDIUM RED SPRAY CAN
821-058C	PAINT GREEN SPRAY CAN
821-066C	PAINT ORANGE SPRAY CAN
821-070C	PAINT GP GLOSS BLACK SPRAY CAN

5. A light coating of oil or grease may be applied to the lower Shank Bars, inside the mold board and inside the side panels in lieu of paint to minimize oxidation.
6. Replace all damaged or missing decals.
7. Store Box Scraper on a level surface in a clean, dry place. Inside storage will reduce maintenance and make for a longer scraper life.

Ordering Replacement Parts

Land Pride offers equipment in factory standard Beige with black highlights. This implement may also be purchased in Orange, Green, or Red.

When ordering an optional color, the suffix number corresponding to the color must be added at the end of the part number. Parts ordered without the suffix number will be supplied in factory standard colors.

81 Green	83 Red
82 Orange	85 Black

For example, if you are ordering a replacement part with part number 555-555C and the existing part is orange, then add the suffix 82 to the end of the number to make the part number read 555-555C82.

BB15 Series

List	Specifications & Capacities		
	BB1560	BB1566	BB1572
Model Numbers			
Working Width	60" (1.52 m)	66" (1.68 m)	72" (1.83 m)
Capacity	12.2 cu. ft. (0.35 cu m)	13.4 cu. ft. (0.38 cu m)	14.7 cu. ft. (0.42 cu m)
Weight	428 lbs (194.1 kg)	450 lbs (204.1 kg)	504 lbs (228.6 kg)
Number of Shanks	4	5	6
Shank Material	3/4" x 2 9/16" x 18" (1.9 cm x 6.5 cm x 45.7 cm) heat treated spring steel		
Vertical Shank Positions	4- positions (2 1/4" & 1/4" (5.7 cm & 6 mm) above and 1 3/4" & 3 3/4" (4.4 cm & 9.5 cm) below scraper end plates)		
Shank Tip Construction	Replaceable heat treated dimpled-on tips		
Shank Beam	4" x 4" x 5/16" (10.2 cm x 10.2 cm x 0.8 cm) Square Tubing with 5/16" x 1" (8 mm x 25 mm) full length shank reinforcements		
Lift Mechanism	4" x 4" x 5/16" (10.2 cm x 10.2 cm x 0.8 cm) Square Tubing with 5/16" x 1" (8 mm x 25 mm) full length shank reinforcements		
Moldboard	Roll-formed moldboard - 17" (43.2 cm) High		
Side Panels	5/16" (8 mm) thick x 16" (40.6 cm) high x 24" (61.0 cm) deep		
Depth of Bucket	22" (55.9 cm)		
Bucket Reinforcement	Two welded braces to rear of bucket		
Cutting Blades	2 ea. 1/2" x 6" (1.3 cm x 15.2 cm) high carbon, heat treated cutting edges; reversible and replaceable		
Maximum H.P. Rating	40 horsepower (29.8 kw)		
A-Frame Material	1/2" x 3" (1.3 cm x 7.6 cm) HR 1021		
3-Point Hitch Type	Double strap lower hitch Cat. I (Fits Land Pride Quick Hitch)		

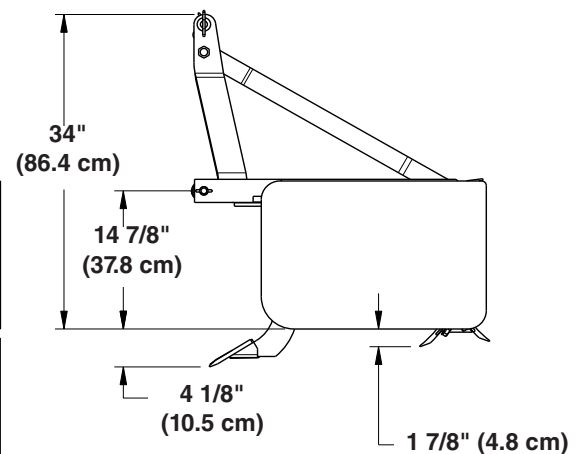
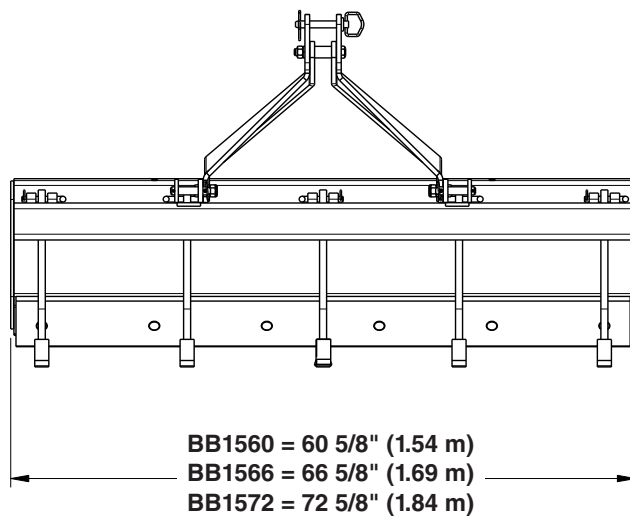

26746

BB25 Series

List	Specifications & Capacities				
Model Numbers	BB2560	BB2566	BB2572	BB2584	BB2596
Working Width	60" (1.52 m)	66" (1.68 m)	72" (1.83 m)	84"(2.13 m)	96" (2.44 m)
Capacity	12.2 cu. ft. (0.35 cu m)	13.4 cu. ft. (0.38 cu m)	14.7 cu. ft. (0.42 cu m)	17.1 cu. ft. (0.48 cu m)	19.6 cu. ft. (0.56 cu m)
Weight	471 lbs (213.6 kg)	500 lbs (226.8 kg)	549 lbs (249.0 kg)	593 lbs (269.0 kg)	658 lbs (298.5 kg)
Number of Shanks	5	5	7	7	8
Shank Material	3/4" x 2 9/16" x 18" (1.9 cm x 6.5 cm x 45.7 cm) Heat Treated Spring Steel				
Vertical Shank Positions	4- positions (2 1/4" & 1/4" (57 mm & 6 mm) above and 1 3/4" & 3 3/4" (4.4 cm & 9.5 cm) below scraper end plates)				
Shank Tip Construction	Replaceable heat treated dimpled-on tips				
Shank Beam	4" x 4" x 5/16" (10.2 cm x 10.2 cm x 8 mm) Square tubing with 5/16" x 1" (8 mm x 25 mm) full length shank reinforcements				
Lift Mechanism	Manual lift with shank pin & hairpin cotter at each shank				
Moldboard	Roll-Formed Moldboard - 17" (43.2 cm) High				
Side Panels	3/8" (10 mm) thick x 16" (40.6 cm) high x 24" (61.0 cm) deep				
Depth of Bucket	22" (55.9 cm)				
Bucket Reinforcement	Two Welded Braces to Rear of Bucket Gusset Between Side Panel and Moldboard				
Cutting Blades	2 ea. 1/2" x 6" (1.3 cm x 15.2 cm) high carbon, heat treated cutting edges; reversible and replaceable				
Maximum H.P. Rating	55 horsepower (41.0 kw)				
A-Frame Material	1/2" x 9" (1.3 cm x 22.9 cm) A36 Flat Bar				
3-Point Hitch Type	Double strap lower hitches Cat. I (Fits Land Pride Quick Hitch)				
Vertical Shank Positions	4				

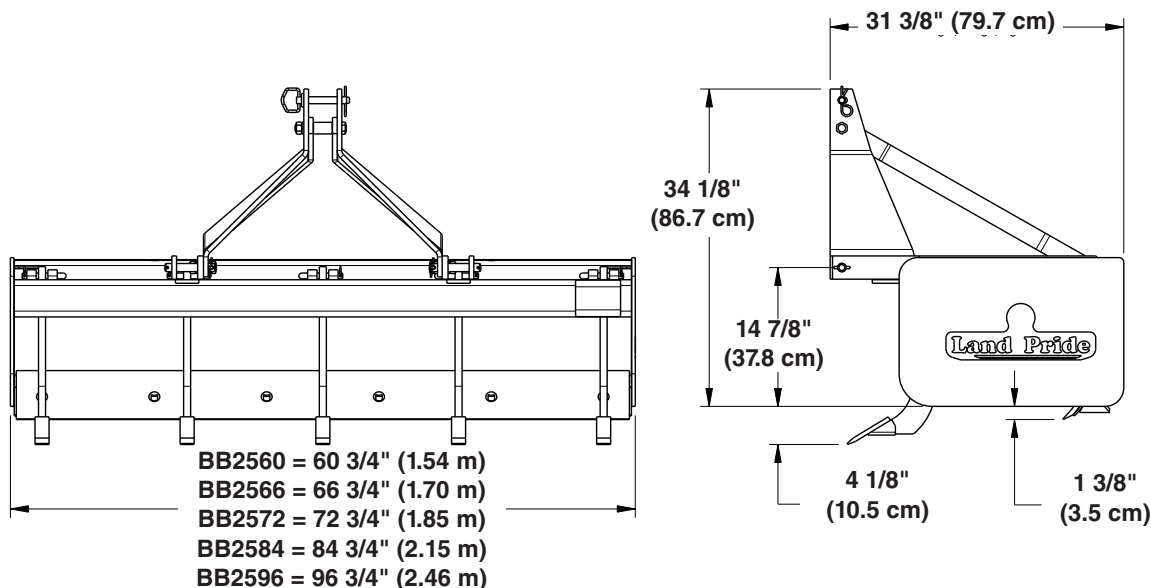

27520

BB15 & BB25 Series

Features	Benefits
5/16" & 3/8" Heavy side panels	Built heavy to handle the tough jobs.
Square tubing shank support	Many competitors use angle iron. Box tubing is stronger.
Clevis -type lower 3-point hitch	Much stronger than pin type hitch.
4 Position heat treated spring steel shanks	Offers flexibility for deep to shallow settings and Heat-treated for longevity.
Working widths	15 Series: 60", 66" & 72" 25 Series: 60", 66", 72", 84" & 96"
horsepower Range	15 Series: 17-40 horsepower 25 Series: 25-55 horsepower
Roll-formed moldboard	Roll-formed moldboard keeps materials flowing which puts less drag on the Box Scraper, resulting in lower horsepower requirements and faster working conditions.
17" Moldboard height	High material capacity.
Moldboard	Heavy moldboard with precise roll holds its shape under heavy loads.
Heat treated dimpled-on tips	Easy to replace tips that are heat treated for toughness.
Heat-treated, reversible, and replaceable cutting blades	Heat-treated for hardness. Reversible so both edges can be used before replacing the cutting blades.
Rear backfill blade	Rear backfill blade allows for backfilling trenches or foundations.
Warranty	One year parts & labor.
Category 1 3-point hitch with Quick Hitch capability	Fits a wide variety of tractors. Quick Hitch capability allows for easy hook-up.
Heavy 4" x 4" X 5/16" front beam with 5/16" x 1" shank hole reinforcement	Reinforcement adds additional strength to shank tube right behind shank where maximum pressure is applied.
Strong Bucket Reinforcement BB15Series	Two welded braces extending from front to rear of bucket help keep the Box Scraper square under heavy loads.
BB25 Series	Two welded braces extending from front to rear of bucket plus welded gussets between the side panels and moldboard provide exceptional strength for keeping the Box Scraper square under heavy loads.

Torque Values Chart for Common Bolt Sizes													
Bolt Size (inches)	Bolt Head Identification						Bolt Size (Metric)	Bolt Head Identification					
	 Grade 2		 Grade 5		 Grade 8			 Class 5.8		 Class 8.8		 Class 10.9	
in-tpi ¹	N · m ²	ft-lb ³	N · m	ft-lb	N · m	ft-lb	mm x pitch ⁴	N · m	ft-lb	N · m	ft-lb	N · m	ft-lb
1/4" - 20	7.4	5.6	11	8	16	12	M 5 X 0.8	4	3	6	5	9	7
1/4" - 28	8.5	6	13	10	18	14	M 6 X 1	7	5	11	8	15	11
5/16" - 18	15	11	24	17	33	25	M 8 X 1.25	17	12	26	19	36	27
5/16" - 24	17	13	26	19	37	27	M 8 X 1	18	13	28	21	39	29
3/8" - 16	27	20	42	31	59	44	M10 X 1.5	33	24	52	39	72	53
3/8" - 24	31	22	47	35	67	49	M10 X 0.75	39	29	61	45	85	62
7/16" - 14	43	32	67	49	95	70	M12 X 1.75	58	42	91	67	125	93
7/16" - 20	49	36	75	55	105	78	M12 X 1.5	60	44	95	70	130	97
1/2" - 13	66	49	105	76	145	105	M12 X 1	90	66	105	77	145	105
1/2" - 20	75	55	115	85	165	120	M14 X 2	92	68	145	105	200	150
9/16" - 12	95	70	150	110	210	155	M14 X 1.5	99	73	155	115	215	160
9/16" - 18	105	79	165	120	235	170	M16 X 2	145	105	225	165	315	230
5/8" - 11	130	97	205	150	285	210	M16 X 1.5	155	115	240	180	335	245
5/8" - 18	150	110	230	170	325	240	M18 X 2.5	195	145	310	230	405	300
3/4" - 10	235	170	360	265	510	375	M18 X 1.5	220	165	350	260	485	355
3/4" - 16	260	190	405	295	570	420	M20 X 2.5	280	205	440	325	610	450
7/8" - 9	225	165	585	430	820	605	M20 X 1.5	310	230	650	480	900	665
7/8" - 14	250	185	640	475	905	670	M24 X 3	480	355	760	560	1050	780
1" - 8	340	250	875	645	1230	910	M24 X 2	525	390	830	610	1150	845
1" - 12	370	275	955	705	1350	995	M30 X 3.5	960	705	1510	1120	2100	1550
1-1/8" - 7	480	355	1080	795	1750	1290	M30 X 2	1060	785	1680	1240	2320	1710
1-1/8" - 12	540	395	1210	890	1960	1440	M36 X 3.5	1730	1270	2650	1950	3660	2700
1-1/4" - 7	680	500	1520	1120	2460	1820	M36 X 2	1880	1380	2960	2190	4100	3220
1-1/4" - 12	750	555	1680	1240	2730	2010							
1-3/8" - 6	890	655	1990	1470	3230	2380							
1-3/8" - 12	1010	745	2270	1670	3680	2710							
1-1/2" - 6	1180	870	2640	1950	4290	3160							
1-1/2" - 12	1330	980	2970	2190	4820	3560							

¹ in-tpi = nominal thread diameter in inches-threads per inch

² N · m = newton-meters

³ ft-lb = foot pounds

⁴ mm x pitch = nominal thread diameter in millimeters x thread pitch

Torque tolerance + 0%, -15% of torquing values. Unless otherwise specified use torque values listed above.

Warranty

Land Pride warrants to the original purchaser that this Land Pride product will be free from defects in material and workmanship beginning on the date of purchase by the end user according to the following schedule when used as intended and under normal service and conditions for personal use.

Overall Unit: One year Parts and Labor

Shanks: Considered wear items.

This Warranty is limited to the repair or replacement of any defective part by Land Pride and the installation by the dealer of any such replacement part, and does not cover common wear items such as blades, belts, tines, etc. Land Pride reserves the right to inspect any equipment or parts which are claimed to have been defective in material or workmanship.

This Warranty does not apply to any part or product which in Land Pride's judgment shall have been misused or damaged by accident or lack of normal maintenance or care, or which has been repaired or altered in a way which adversely affects its performance or reliability, or which has been used for a purpose for which the product is not designed. Misuse also specifically includes failure to properly maintain oil levels, grease points, and driveline shafts.

Claims under this Warranty must be made to the dealer which originally sold the product and all warranty adjustments must be made through such dealer. Land Pride reserves the right to make changes in materials or design of the product at any time without notice.

This Warranty shall not be interpreted to render Land Pride liable for damages of any kind, direct, consequential, or contingent to property. Furthermore, Land Pride shall not be liable for damages resulting from any cause beyond its reasonable control. This Warranty does not extend to loss of crops, any expense or loss for labor, supplies, rental machinery or for any other reason.

No other warranty of any kind whatsoever, express or implied, is made with respect to this sale; and all implied warranties of merchantability and fitness for a particular purpose which exceed the obligations set forth in this written warranty are hereby disclaimed and excluded from this sale.

This Warranty is not valid unless registered with Land Pride within 30 days from the date of purchase.

IMPORTANT: The Online Warranty Registration should be completed by the dealer at the time of purchase. This information is necessary to provide you with quality customer service.

Model Number _____ **Serial Number** _____



Corporate Office: P.O. Box 5060
Salina, Kansas 67402-5060 USA
www.landpride.com
